

VELIA

LUMINARIA LINEAL LED



Más rápido de instalar,
más libre para diseñar.

VELIA

Más rápido de instalar,
mas libre para diseñar.

VELIA es una solución de iluminación lineal concebida para integrarse con naturalidad en proyectos de interior, donde el diseño, la funcionalidad y la versatilidad son elementos clave.

Su estética limpia y depurada, junto con su formato rectangular, permite crear composiciones elegantes, continuas y perfectamente alineadas con las necesidades del espacio.

La serie se presenta en cuatro longitudes estándar (600, 1200, 1500 y 1800 mm) y dos acabados (blanco y negro), facilitando su integración en múltiples entornos.

Una de las principales características de **VELIA** es la rapidez y sencillez de instalación, así como la facilidad para ampliar, adaptar o reconfigurar el sistema según las necesidades del proyecto. Su concepción modular permite enlazar perfiles de forma ágil, precisa e intuitiva, optimizando los tiempos de montaje y simplificando la instalación.

A esta flexibilidad se suma otro de los conceptos fundamentales de la serie: una familia desarrollada a partir de un cuerpo común, concebido como base para generar múltiples soluciones con sus diferentes difusores –opal, microprismático, panel de abeja, antideslumbrante, rejilla o bañador de pared–.

Además, en términos de sostenibilidad, optimiza materiales y racionaliza componentes, dando lugar a una solución más eficiente, coherente y responsable.







Este planteamiento permite adaptar **VELIA** a distintos requisitos de eficiencia, confort visual, efecto lumínico y acabado final, manteniendo la coherencia estética en todo el proyecto.

Con una completa gama de accesorios de unión en L, 120°, T, Y y X, **VELIA** no solo resuelve líneas continuas de luz, sino que ofrece libertad para crear composiciones más dinámicas, creativas y adaptadas a cada espacio.

Disponible para instalación en superficie, suspensión y pared, **VELIA** reúne diseño, funcionalidad y capacidad de configuración en una misma serie, convirtiéndose en una solución versátil para proyectos que buscan una iluminación lineal contemporánea.

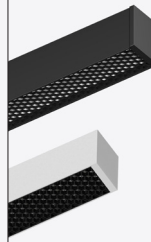
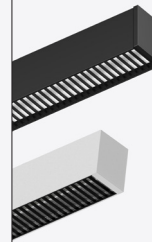

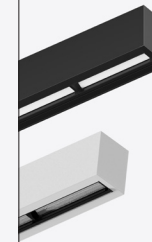
VELIA. CARACTERÍSTICAS

												
	VELIA OPAL		VELIA MICROPRISMÁTICO		VELIA HONEYCOMB		VELIA ANTIDESLUMBRANTE		VELIA REJILLA		VELIA BAÑADOR PARED	
	VLA OP		VLA MP		VLA HN		VLA LV		VLA GR		VLA WW	
POTENCIA / LONGITUD	W	mm	W	mm	W	mm	W	mm	W	mm	W	mm
	20	616	20	616	20	616	20	616	20	616	20	679
	40	1216	40	1216	40	1216	40	1216	40	1216	40	1210
	50	1516	50	1516	50	1516	50	1516	—	—	—	—
	60	1816	60	1816	60	1816	60	1816	—	—	—	—
EFICIENCIA	Hasta 114 lm/W		Hasta 110 lm/W		Hasta 28 lm/W		Hasta 50 lm/W		Hasta 120 lm/W		Hasta 76 lm/W	
CCT SWITCH 	● 3000K / ● 4000K / ● 5700K											
ACABADO	Blanco (RAL 9003) / Negro (RAL 9005)											
ÁNGULO	110°		90°		48°		60°		80°		80°	
UGR			<19		<19		<19		<19			
OPCIONES DE REGULACIÓN	1-10V / PUSH DALI-2 / PUSH											
VIDA ÚTIL	50.000 h L80B50											
CRI	>80											
IP	IP20											
PARPADEO	Flicker Free											
TEMPERATURA DE TRABAJO	-20°C ~ +40°C											
TIPO DE INSTALACIÓN (ACCESORIOS)	Superficie / Suspensión / Pared											
INSTALACIÓN DIRECTA A TECHO (SIN ACCESORIOS)	✓		✓		✓		✓					
UNIONES	L / 120° / T / Y / X											
GARANTÍA	5 años											

VELIA. CARACTERÍSTICAS



Hasta
120 lm/W reales

Driver



Conector rápido

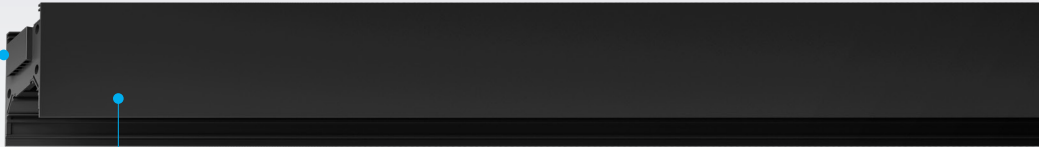

Cuerpo de aluminio

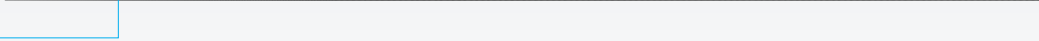

PCB CCT



TIPOS DE DIFUSOR

Difusor Opal

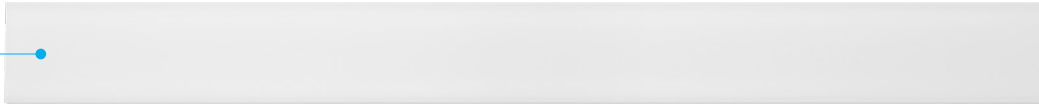

Difusor Microprismático

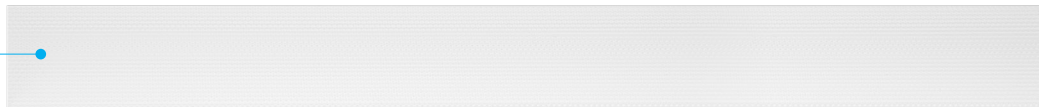

Honeycomb



Antideslumbrante



Rejilla



Bañador de pared



• CCT Switch



CCT SWITCH

- 5700K
- 4000K
- 3000K

• Ángulos



HONEYCOMB



ANTIDESLUMBRANTE



REJILLA Y BAÑADOR PARED



MICROPRISMÁTICO



OPAL

• Opc. de regulación



1-10V / PUSH



DALI-2 / PUSH

• Opcional



UE DRIVER

• Material



CUERPO



DIFUSOR Y REFLECTOR

• Accesorios instalación



SUPERFICIE



SUSPENSIÓN



PARED

• Accesorios de unión



UNIÓN L 90°



UNIÓN L 120°



UNIÓN T



UNIÓN Y



UNIÓN X

VELIA. CARACTERÍSTICAS

SIN TRAMOS ESPECÍFICOS
Funciona como luminaria individual o como sistema lineal continuo.

FÁCIL INSTALACIÓN
Su conector rápido permite el montaje en línea en solo **2 segundos**.

Incluye accesorio para evitar fugas de luz en las uniones

CCT SWITCH
Selector de CCT en la parte superior para cambiar la temperatura de color entre 3000K / 4000K / 5700K

Surface-mounted installation holes

ACCESORIOS DE INSTALACIÓN

SUPERFICIE

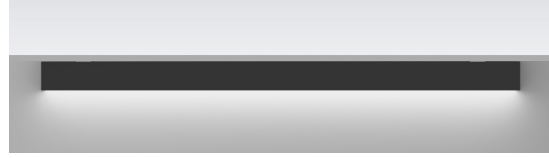

SUSPENSIÓN



PARED



INSTALACIÓN EN SUPERFICIE DIRECTA A TECHO

Con orificio interior para la fijación directa a techo sin necesidad del accesorio de superficie.
(Excepto en los modelos: Rejilla y Bañador de pared)

ACABADO EN BLANCO Y NEGRO

Todas las luminarias y los accesorios están disponibles en los dos acabados.

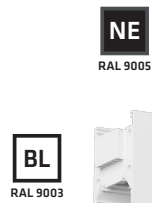

ACCESORIOS DE UNIÓN

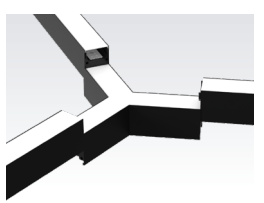
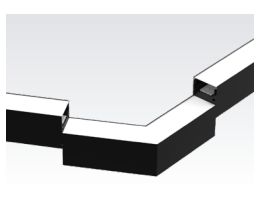
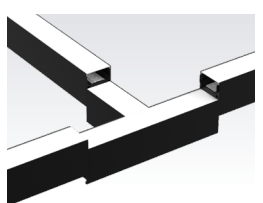
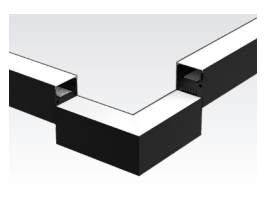
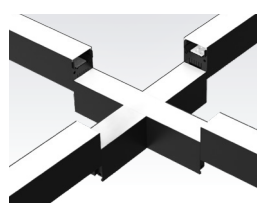

UNIÓN X

UNIÓN L 90°

UNIÓN T

UNIÓN 120°

UNIÓN Y

VELIA OPAL

PRD VLA OP



• Material



• Certificaciones

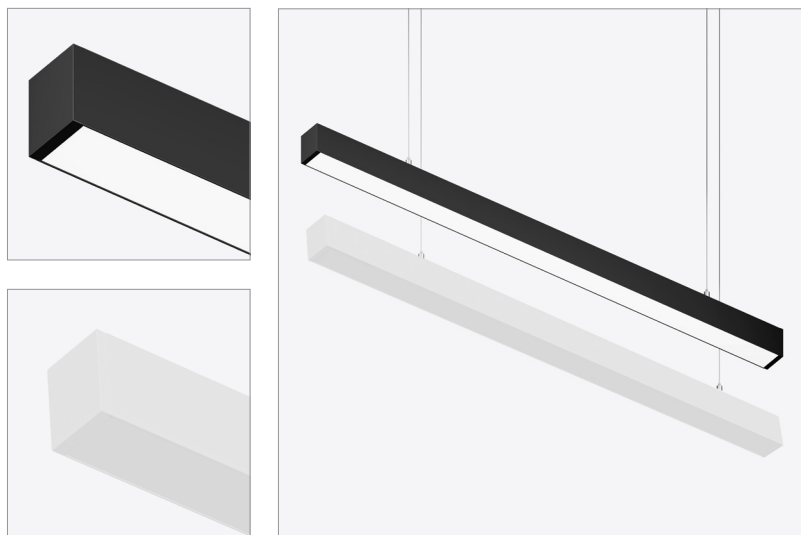

• Opciones de regulación



• Opcional



• Accesorios instalación

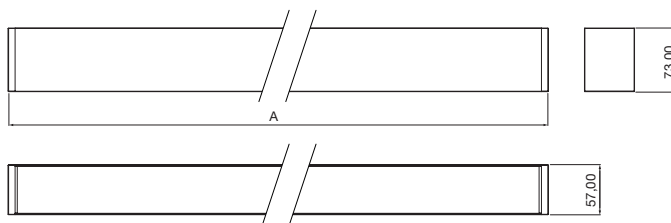
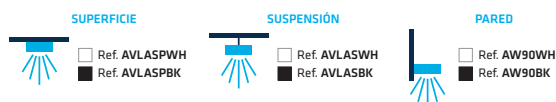

• Accesorios unión (Pg. 12-14)

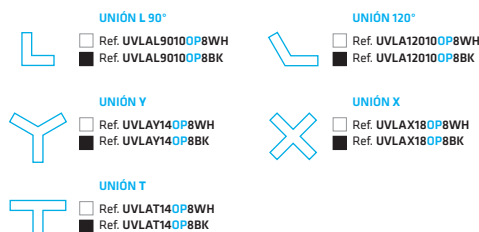

	A
VLA06	616
VLA12	1216
VLA15	1516
VLA18	1816

Medidas (mm).



Modelo	Opciones	W	CCT	2626 lm	2226 lm
VLA0620OP8WH	<input type="checkbox"/> *	20 W	5700K	2626 lm	2226 lm
VLA0620OP8BK	<input checked="" type="checkbox"/> *		4000K	2653 lm	2253 lm
			3000K	2460 lm	2160 lm
VLA1240OP8WH	<input type="checkbox"/> *	40 W	5700K	5232 lm	4432 lm
VLA1240OP8BK	<input checked="" type="checkbox"/> *		4000K	5344 lm	4544 lm
			3000K	4810 lm	4210 lm
VLA1550OP8WH	<input type="checkbox"/> *	50 W	5700K	6585 lm	5585 lm
VLA1550OP8BK	<input checked="" type="checkbox"/> *		4000K	6693 lm	5693 lm
			3000K	6097 lm	5347 lm
VLA1860OP8WH	<input type="checkbox"/> *	60 W	5700K	7898 lm	6698 lm
VLA1860OP8BK	<input checked="" type="checkbox"/> *		4000K	8016 lm	6816 lm
			3000K	7221 lm	6321 lm

* Opciones de regulación

* Opcional

D1 1-10V / PUSH D2 DALI-2 / PUSH

UE UE DRIVER

VELIA MICROPRISMÁTICO

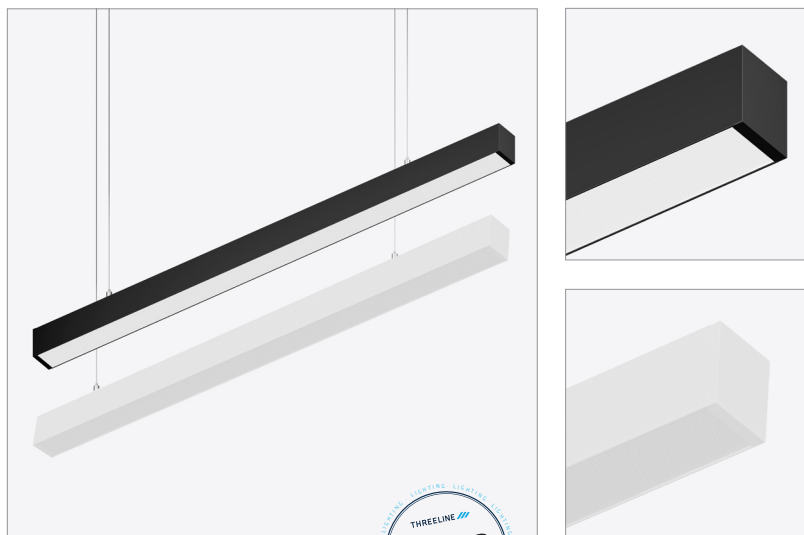

THREELINE
UGR < 19

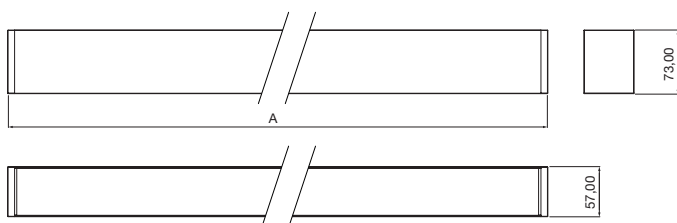

	A
VLA06	616
VLA12	1216
VLA15	1516
VLA18	1816

Medidas (mm).



CCT SWITCH

IIIIII		OPCIONES	W	CCT		
VLA0620MP8WH	<input type="checkbox"/>	*	20 W	● 5700K	2563 lm	2163 lm
VLA0620MP8BK	<input checked="" type="checkbox"/>	*		● 4000K ● 3000K	2632 lm	2232 lm
VLA1240MP8WH	<input type="checkbox"/>	*	40 W	● 5700K	4723 lm	3923 lm
VLA1240MP8BK	<input checked="" type="checkbox"/>	*		● 4000K ● 3000K	4989 lm	4189 lm
VLA1550MP8WH	<input type="checkbox"/>	*	50 W	● 5700K	6325 lm	5325 lm
VLA1550MP8BK	<input checked="" type="checkbox"/>	*		● 4000K ● 3000K	6410 lm	5410 lm
VLA1860MP8WH	<input type="checkbox"/>	*	60 W	● 5700K	7575 lm	6375 lm
VLA1860MP8BK	<input checked="" type="checkbox"/>	*		● 4000K ● 3000K	7800 lm	6600 lm
					7186 lm	6286 lm

* Opciones de regulación

D1 1-10V / PUSH D2 DALI-2 / PUSH

* Opcional

UE UE DRIVER

PRO VLA MP



• Material



• Certificaciones



• Opciones de regulación



• Opcional



• Accesorios instalación

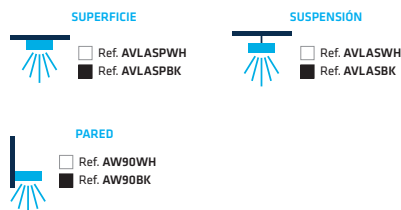

VELIA HONEYCOMB

PRO VLA HN



• Material



• Certificaciones



• Opciones de regulación



• Opcional



• Accesorios instalación

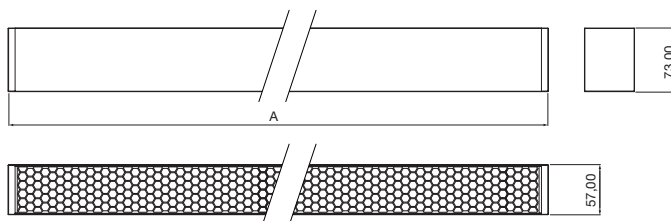
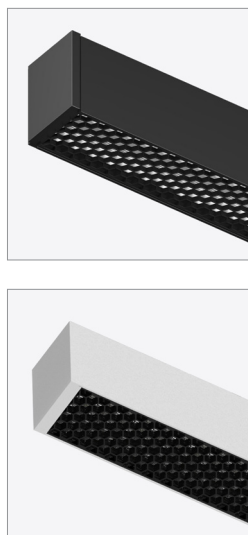
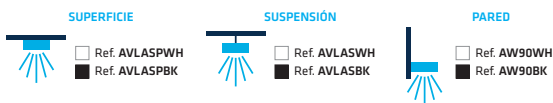

	A
VLA06	616
VLA12	1216
VLA15	1516
VLA18	1816

Medidas (mm).



Modelo	Opciones	W	CCT	Beam Angle	Distance
VLA0620HN8WH	<input type="checkbox"/>	20 W	5700K	897 lm	479 lm
VLA0620HN8BK	<input checked="" type="checkbox"/>		4000K	905 lm	505 lm
			3000K	795 lm	495 lm
VLA1240HN8WH	<input type="checkbox"/>	40 W	5700K	2080 lm	1138 lm
VLA1240HN8BK	<input checked="" type="checkbox"/>		4000K	1970 lm	1170 lm
			3000K	1674 lm	1074 lm
VLA1550HN8WH	<input type="checkbox"/>	50 W	5700K	2346 lm	1346 lm
VLA1550HN8BK	<input checked="" type="checkbox"/>		4000K	2452 lm	1452 lm
			3000K	2040 lm	1290 lm
VLA1860HN8WH	<input type="checkbox"/>	60 W	5700K	2776 lm	1575 lm
VLA1860HN8BK	<input checked="" type="checkbox"/>		4000K	2881 lm	1681 lm
			3000K	2397 lm	1497 lm

* Opciones de regulación

D1 1-10V / PUSH D2 DALI-2 / PUSH

* Opcional

UE UE DRIVER

VELIA ANTIDESLUMBRANTE



THREELINE
UGR < 19

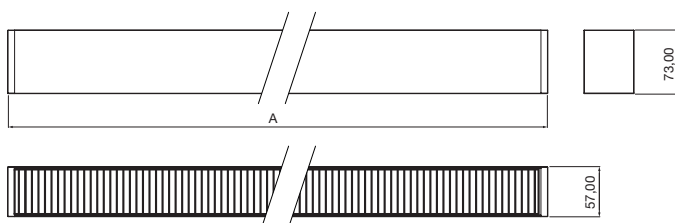

	A
VLA06	616
VLA12	1216
VLA15	1516
VLA18	1816

Medidas (mm).



CCT SWITCH

IIIIII		OPCIONES	W	CCT		
VLA0620LV8WH	<input type="checkbox"/>	*	20 W	● 5700K	1451 lm	1051 lm
VLA0620LV8BK	<input checked="" type="checkbox"/>	*		● 4000K ● 3000K	1457 lm	1057 lm
VLA1240LV8WH	<input type="checkbox"/>	*	40 W	● 5700K	2534 lm	1814 lm
VLA1240LV8BK	<input checked="" type="checkbox"/>	*		● 4000K ● 3000K	2660 lm	1860 lm
VLA1550LV8WH	<input type="checkbox"/>	*	50 W	● 5700K	3398 lm	2398 lm
VLA1550LV8BK	<input checked="" type="checkbox"/>	*		● 4000K ● 3000K	3519 lm	2516 lm
LA1860LV8WH	<input type="checkbox"/>	*	60 W	● 5700K	4012 lm	2812 lm
VLA1860LV8BK	<input checked="" type="checkbox"/>	*		● 4000K ● 3000K	4204 lm	3004 lm

* Opciones de regulación

D1 1-10V / PUSH D2 DALI-2 / PUSH

* Opcional

UE UE DRIVER

PRO VLA LV



• Material



• Certificaciones



• Opciones de regulación



• Opcional



• Accesorios instalación

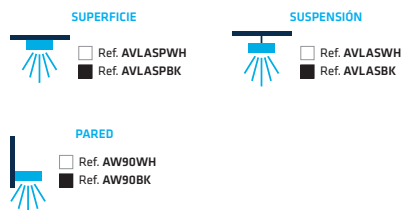

VELIA REJILLA

PRO VLA GR



• Material



• Certificaciones



• Opciones de regulación



• Opcional



• Accesorios instalación

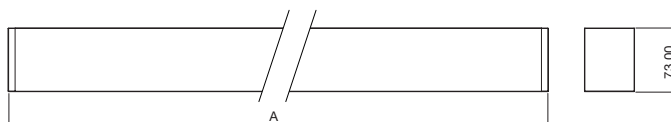
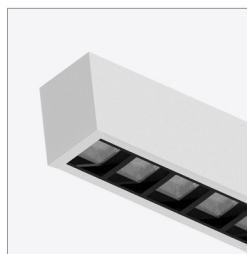
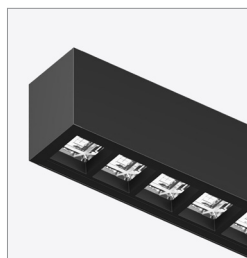
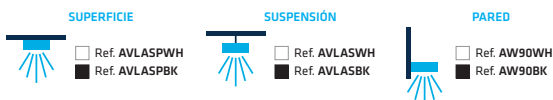

	A
VLA06	616
VLA12	1216

Medidas (mm).



CCT SWITCH

Modelo	Opciones	W	CCT	Beam Angle	Beam Angle
VLA0620GR8WH	<input type="checkbox"/>	20 W	● 5700K	2616 lm	2216 lm
VLA0620GR8BK	<input checked="" type="checkbox"/>		● 4000K	2324 lm	2324 lm
			● 3000K	2464 lm	2164 lm
VLA1240GR8WH	<input type="checkbox"/>	40 W	● 5700K	5246 lm	4446 lm
VLA1240GR8BK	<input checked="" type="checkbox"/>		● 4000K	5172 lm	4792 lm
			● 3000K	4972 lm	4372 lm

* Opciones de regulación

D1 1-10V / PUSH D2 DALI-2 / PUSH

* Opcional

UE UE DRIVER

VELIA BAÑADOR PARED



PRO VLA WW



• Material



• Certificaciones

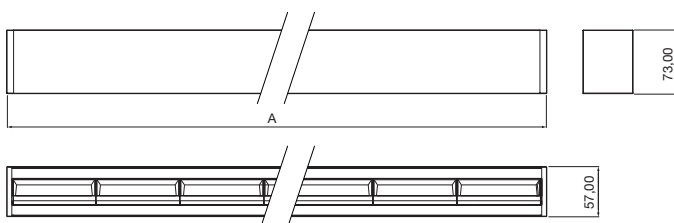

	A
VLA06	679
VLA12	1210

Medidas (mm).

• Opciones de regulación



• Opcional



• Accesorios instalación

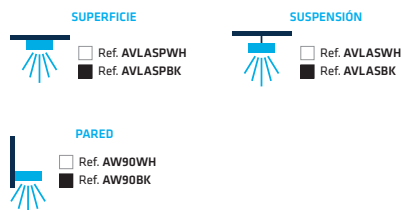

CCT SWITCH

IIIIII	OPCIONES	W	CCT	lm	lm
VLA0620WW8WH	<input type="checkbox"/>	20 W	● 5700K	1819 lm	1419 lm
VLA0620WW8BK	<input checked="" type="checkbox"/>		● 4000K ● 3000K	1927 lm	1527 lm
VLA1240WW8WH	<input type="checkbox"/>	40 W	● 5700K	3609 lm	2809 lm
VLA1240WW8BK	<input checked="" type="checkbox"/>		● 4000K ● 3000K	4001 lm	3201 lm
				3326 lm	2726 lm

* Opciones de regulación

D1 1-10V / PUSH D2 DALI-2 / PUSH

* Opcional

UE UE DRIVER

VELIA UNIÓN L 90°

PRO UVLA L90

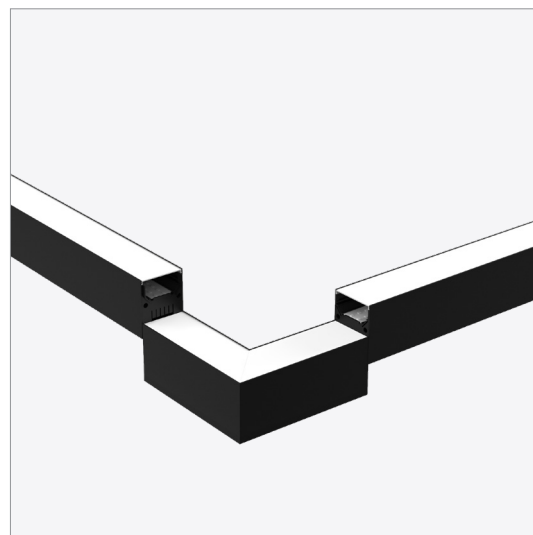
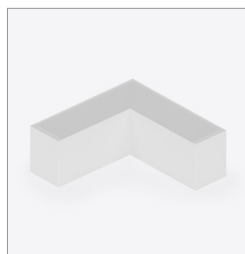
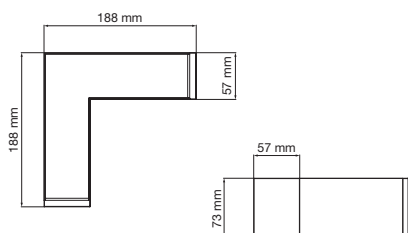

Icon	W	CCT	Beam Angle	Light Output
UVLAL9010OP8WH	10 W	5700K	110°	1286 lm
UVLAL9010OP8BK		4000K	110°	1310 lm
		3000K	110°	1208 lm

VELIA UNIÓN 120°

PRO UVLA 120

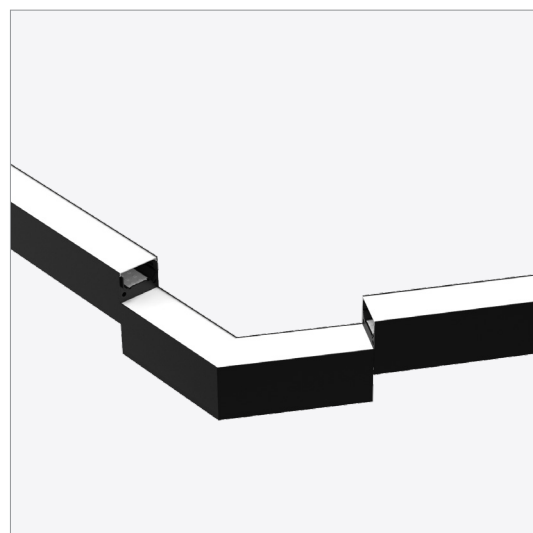
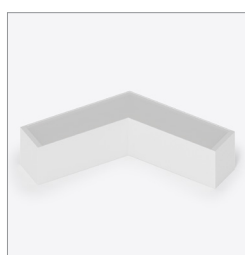
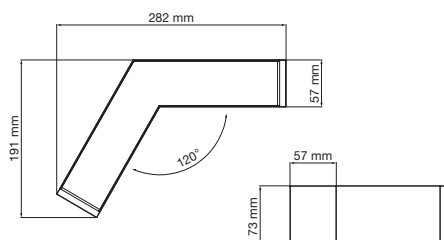

Icon	W	CCT	Beam Angle	Light Output
UVLA12010OP8WH	10 W	5700K	110°	1296 lm
UVLA12010OP8BK		4000K	110°	1246 lm
		3000K	110°	1412 lm

• Material



• Certificaciones



• Accesorios instalación

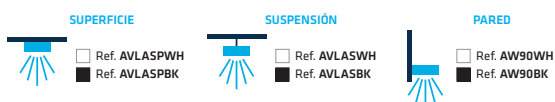

VELIA UNIÓN T

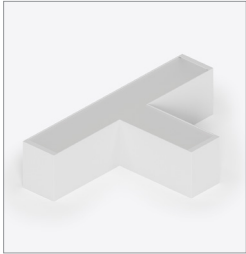
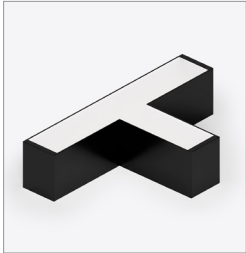
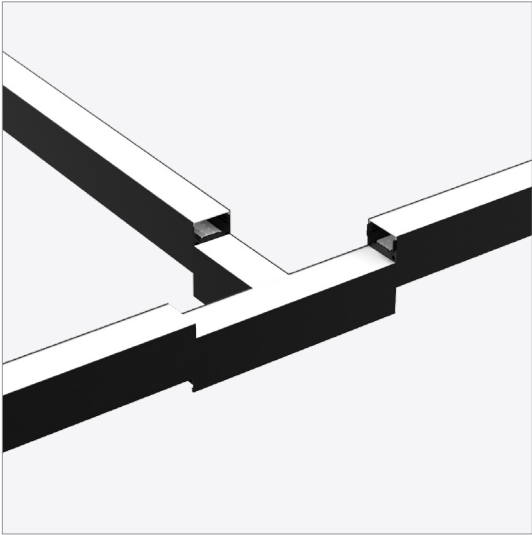

PRO UVLA T

CCT SWITCH
 220-240Vac 50/60Hz
 FLICKER FREE
 110°
 5 AÑOS GARANTÍA
 50.000 h
 x 10.000
 IP20
 DI
 BL RAL 9003
 NE RAL 9005

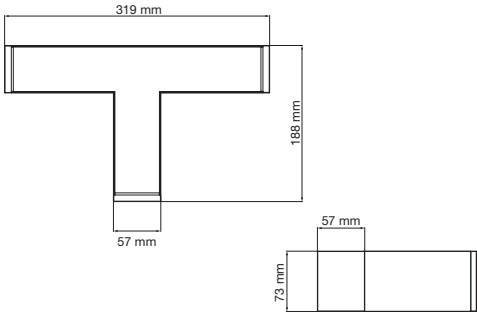

Icon	W	CCT	Beam Angle	Light Output
UVLAT14OP8WH	14 W	5700K	1793 lm	1513 lm
UVLAT14OP8BK	14 W	4000K	1847 lm	1567 lm
		3000K	1694 lm	1484 lm

VELIA UNIÓN Y

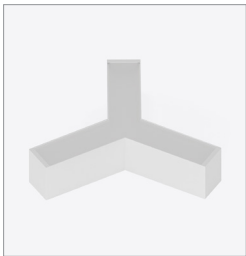
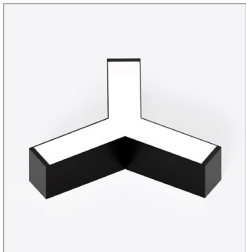
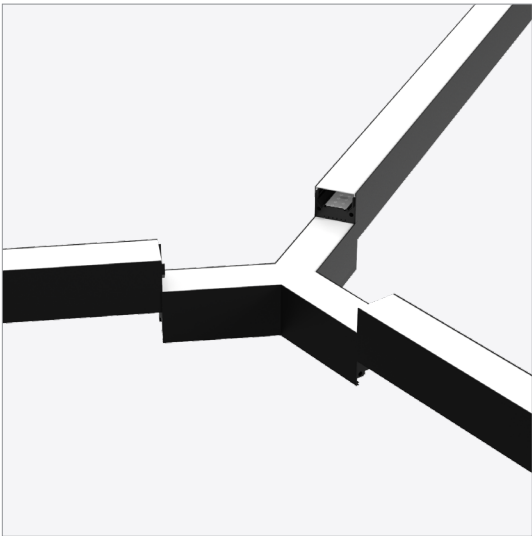

PRO UVLA Y

CCT SWITCH
 220-240Vac 50/60Hz
 FLICKER FREE
 110°
 5 AÑOS GARANTÍA
 50.000 h
 x 10.000
 IP20
 DI
 BL RAL 9003
 NE RAL 9005

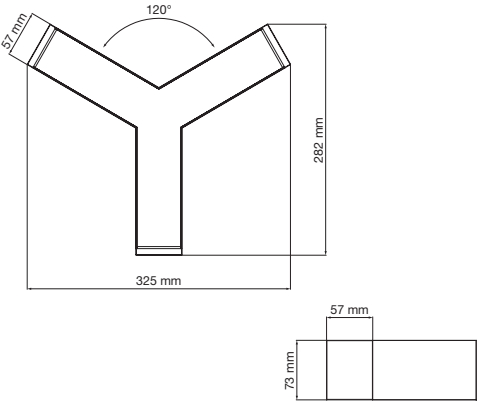

Icon	W	CCT	Beam Angle	Light Output
UVLAY14OP8WH	14 W	5700K	1813 lm	1533 lm
UVLAY14OP8BK	14 W	4000K	1847 lm	1567 lm
		3000K	1699 lm	1490 lm

• Material



• Certificaciones



• Accesorios instalación

SUPERFICIE
 Ref. AVLASPWH (White)
 Ref. AVLASPBK (Black)

SUSPENSIÓN
 Ref. AVLASWH (White)
 Ref. AVLASBK (Black)

PARED
 Ref. AW90WH (White)
 Ref. AW90BK (Black)

VELIA UNIÓN X

PRO UVLAX

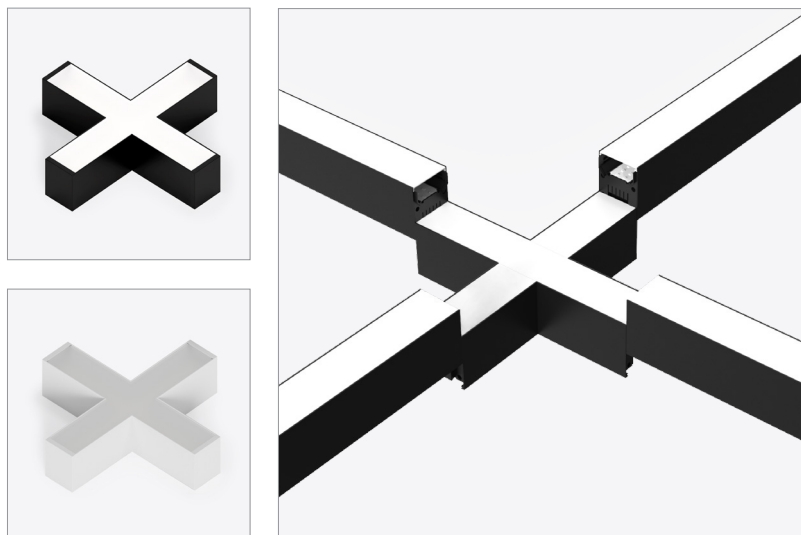
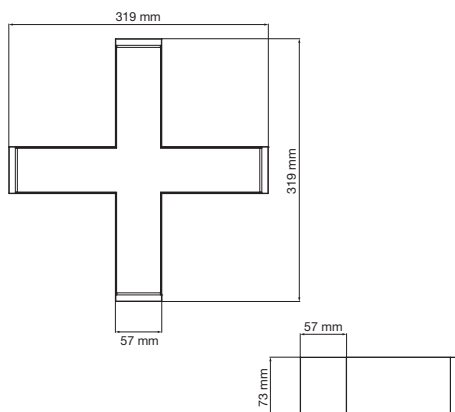

Icon	W	CCT	Beam Angle	Light Output
UVLAX180P8WH	18 W	5700K	2267 lm	1907 lm
UVLAX180P8BK		4000K	2327 lm	1967 lm
		3000K	2141 lm	1871 lm

• Material



• Certificaciones



• Accesorios instalación

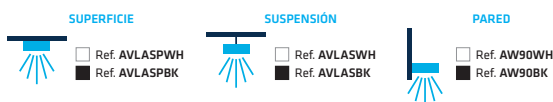

VELIA ACCESORIOS INSTALACIÓN

SUPERFICIE



- Ref. **AVLASPWH** (2 uds.)
- Ref. **AVLASPBK** (2 uds.)

SUSPENSIÓN



- Ref. **AVLASWH** (2 uds.)
- Ref. **AVLASBK** (2 uds.)

PARED



- Ref. **AW90WH** (2 uds.)
- Ref. **AW90BK** (2 uds.)

Suspensión



Superficie



Bañador de pared

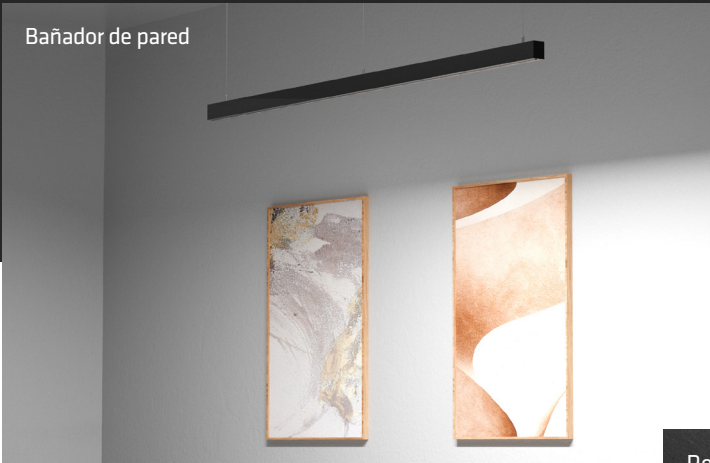

Pared

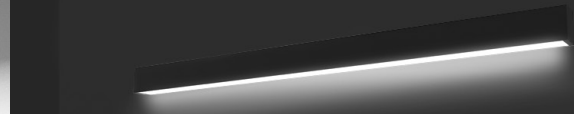

Honeycomb



Rejilla

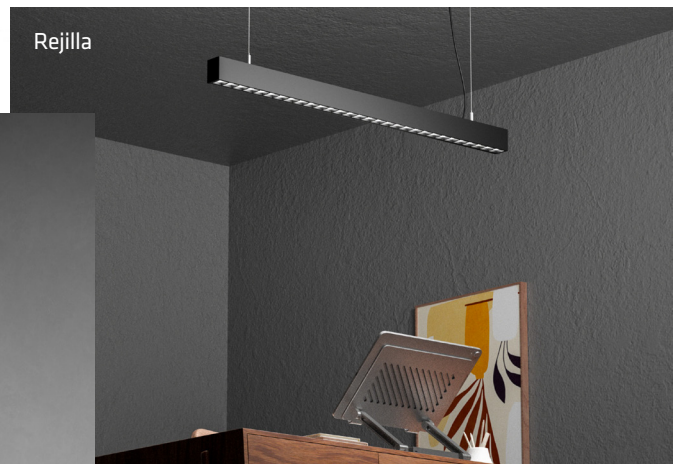

Composición Opal / Honeycomb

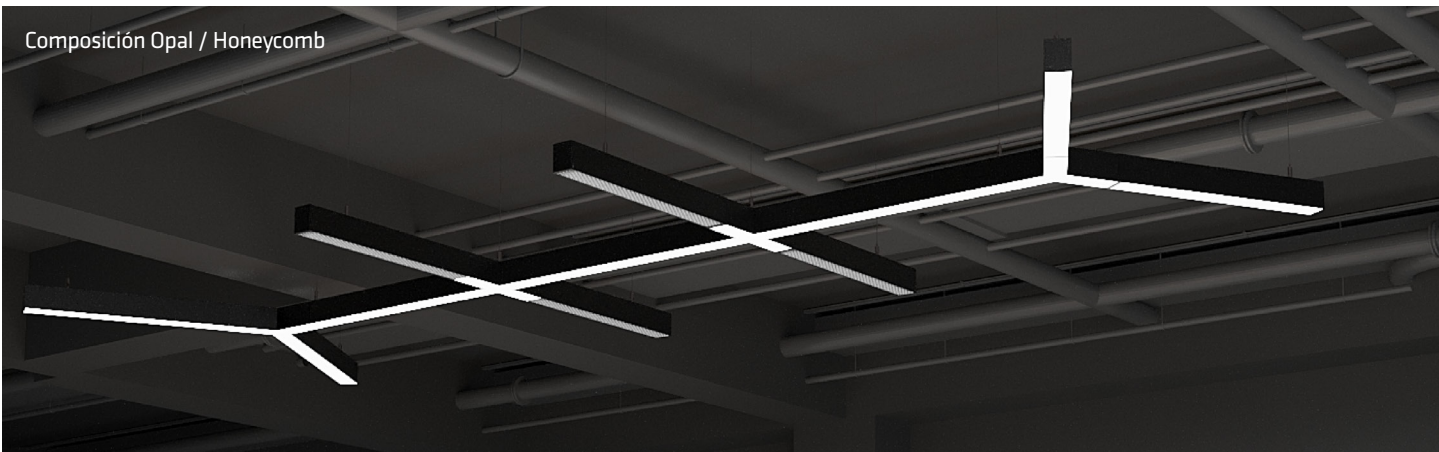

VELIA

THREELINE 



ThreelineGroup.com